

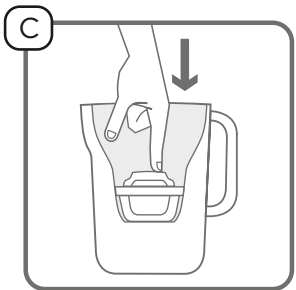

Instruction for use

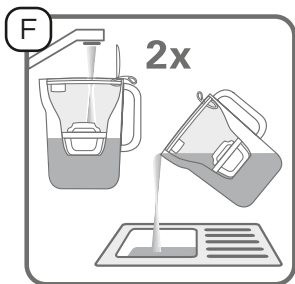

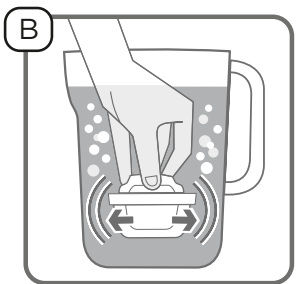

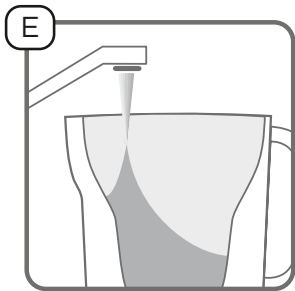
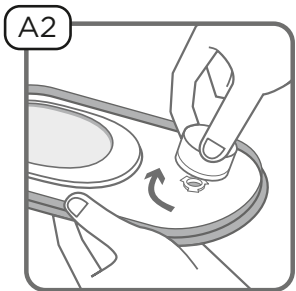
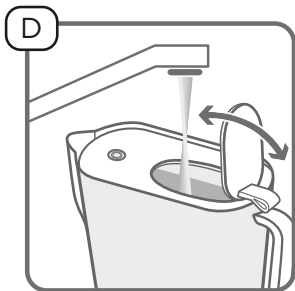
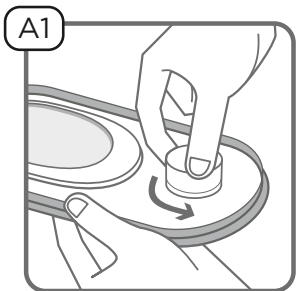
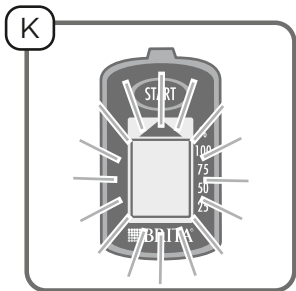
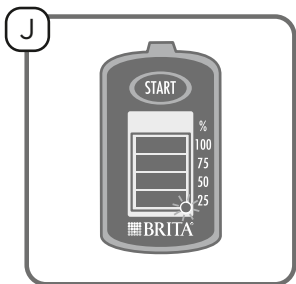
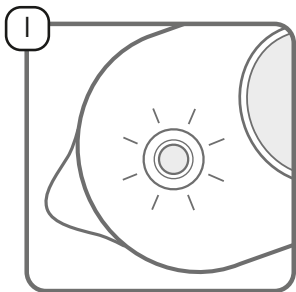
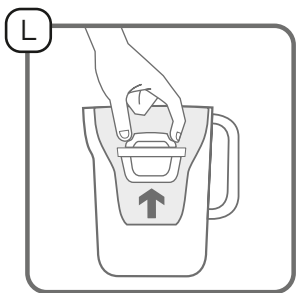
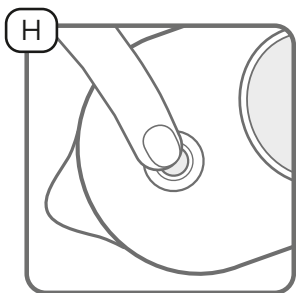
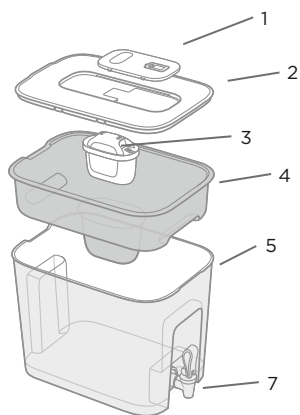
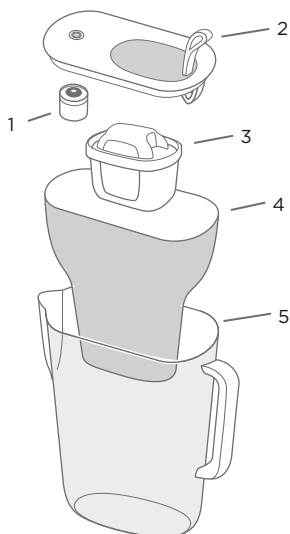
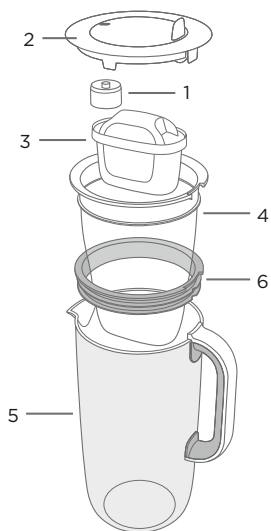

- EN**
1. Water filter exchange indicator
 2. Lid
 3. MAXTRA PRO water filter
 4. Funnel
 5. Jug/Tank
 6. Silicone sealing ring
 7. Tap spout

Hello and thank you very much for choosing BRITA.

BRITA filtered water – for you, your family and the environment!
Have fun using your new product!



All of our expert knowledge with MAXTRA PRO water filters:
Super-fine mesh captures coarse particles from old pipeworks and the **additional high-performance filter mesh** retains even the finest* particles ($\geq 30 \mu\text{m}$) from tap water.

Powerful Ion-exchange pearls

- for softer water, to protect your appliances*
- for the reduction of metals such as lead and copper

Natural MicroCarbon from coconut shells

- reduces odour- and taste-impairing substances such as chlorine
- provides great-tasting, freshly filtered water*

The maximum lifespan of a MAXTRA PRO water filter is 150 litres or 4 weeks.

Acting sustainably is especially important to us



That's why our water filters are recyclable.
Find out more at brita.net



Optimum filter performance



Please only filter cold tap water.

Please only use BRITA water filters with tap water from municipal water treatment plants – only this meets the legal requirements for drinking water quality.

Important: store filtered water in a cool place and use within 24 hours.

Official advice for boiling tap water also applies to BRITA filtered water. The rule is: filter first, then boil!

If this advice no longer applies, please clean the jug thoroughly and insert a new water filter.

For certain groups of people (e.g. babies and people with impaired immunity) it is generally recommended that tap water should be boiled.

Highest quality & hygiene

Over 50 years of water filter experience stands for:

- ✓ Innovation
- ✓ the highest quality

In order to meet our high quality standards, there are strict internal and external quality controls in place.

Every MAXTRA PRO water filter undergoes treatment with hot steam for hygiene purposes during manufacture and is then packed in a protective foil. (Note: the water filter may be damp due to condensation following the steam treatment).

The MAXTRA PRO water filter's material is specially treated with silver. As a result, trace amounts of silver may be released into the water; however, these levels remain well below the limits set by the World Health Organization (WHO).

BRITA recommends replacing the water filter regularly.

Please follow the recommended cleaning procedures and advice on preparing the filter (chapters 1-7).

The jug should be cleaned regularly.

Note

If the jug is not being used for a while, remove the water filter, empty the jug and replace the water filter loosely in the empty funnel.

Please refer to chapter 7 "Changing the MAXTRA PRO water filter".

Operation - very easy

1 Clean before the first use and every time you change the water filter

For optimum cleaning results, turn the BRITA PerfectFit funnel upside down and flush the BRITA PerfectFit mechanism with tap water for a few seconds (excluding BRITA Flow).

The jug should be cleaned before the first use and when you change the water filter - the funnel and jug are dishwasher safe (max. 50° C) or can be cleaned by hand!

Please clean your BRITA Flow only by hand with cold or lukewarm water.

Lid with BRITA Smart Light +

Please remove the BRITA Smart Light before cleaning the lid (turn counter-clockwise).

The BRITA Smart Light must not be washed in the dishwasher! Remove the BRITA Smart Light by hand and clean with a soft, damp cloth.

Lid with non-removable BRITA Memo **J**

Please clean the lid by hand, as it is not dishwasher safe!

2 Preparing the MAXTRA PRO water filter **B**

Fill the clean jug with cold water.

Immerse the water filter and shake slightly to remove any excess air. Remove the water filter and pour away the water in the jug.

Done!

3 Inserting the MAXTRA PRO water filter **C**

The BRITA PerfectFit System has been developed to create a perfect fit and seal between the MAXTRA PRO water filter and the funnel.

Insert the funnel into the jug and place the water filter firmly in the funnel. Please push the water filter further downwards if the water does not flow through.

BRITA can only guarantee optimum filtration if BRITA MAXTRA PRO water filters are used.

The BRITA PerfectFit System is not included in BRITA Flow.

4 Filling the BRITA water filter jug **D** **E**

The water in the funnel is filtered automatically and flows into the jug.

How the jug is filled will depend on the model or the type of lid.

5 Activating the MAXTRA PRO water filter **F**

For optimal taste and performance please allow two full funnels of tap water to pass through the filter before drinking.

To join BRITA in considering the environment, you can use this filtered water to water your plants, for example.

6 Setting the water filter exchange indicator

How handy! The BRITA water filter jug will tell you when you need a new water filter.

There are different exchange indicators for this in the lid:

BRITA Smart Light **G** **H** **I**

Its intelligent sensor not only measures the time since the water filter was last replaced, but also records the volume of filtered water.

Before using the jug for the first time (and after every time you change the water filter), press the BRITA Smart Light reset button for approx. 5-10 seconds until the LED indicator flashes green three times.

The jug is now ready to use.

The flashing light indicates when you should replace the filter:

Green: The water filter is filtering optimally.

Yellow: It will soon be time to change the water filter. Think about purchasing a new one!

Red: Please change the water filter!

You can check your filter status at any time by pressing briefly on the BRITA Smart Light.

BRITA Memo

Remove the protective foil before using BRITA Memo for the first time.

After activating the water filter, press and hold the „START“ button until four bars appear on the display and flash twice.

The flashing dot in the bottom right of the display unit means: “Memo in operation”.

A new water filter is required if the empty display unit flashes.

Changing the MAXTRA PRO water filter

Simply remove the water filter and follow steps 1 to 6 of the instructions.

Important information

Never place the BRITA water filter jug and the MAXTRA PRO water filter in full sun and keep away from heating elements (e.g. kettles or conventional ovens).



It is better to store them in a dark, cool and dry place (and keep new water filters in their original packaging). Store the BRITA Smart Light out of the reach of children (risk of swallowing)!

Sensitive to potassium?

Filtering initially causes a slight elevation in the potassium content of the water. This is harmless (e.g. 1 L of BRITA filtered water contains less potassium than an apple).

Please consult your doctor before using a BRITA water filter if you suffer from kidney disease or have to follow a special low-potassium diet.

Natural traces

The BRITA activated carbon beads are of natural origin and so natural variations may occur.

A low volume of small carbon particles can get into the filtered water, which you may see as black particles.

These particles are not harmful to your health because they pass naturally through the body unchanged if swallowed.

If you discover carbon particles in your filtered water, BRITA recommends rinsing the water filter until there are no more particles visible.

Disposal and spare parts

The BRITA Smart Light and BRITA Memo use batteries (lifespan of approx. 5 years).

The exchange indicator should be removed at the end of its lifespan and disposed of properly in accordance with the statutory regulations.



BRITA Smart Light

Rotate counter-clockwise and remove from the lid.

BRITA Memo

Lift out using a screwdriver (please only remove it for the purpose of disposal).

BRITA water filter jug and water filter

Please dispose of the water filter jug and cartridge responsibly, following local guidelines. Ensure the cartridge remains unopened.

Sustainability is important to us

We will be happy to supply you with spare parts to extend the lifecycle of our products.

Please contact the BRITA customer services or your local distributor if you have any questions about spare parts.

Exclusion of liability

We ask for your understanding that BRITA does not accept any liability if the information in the usage instructions is not followed.

Do you have any further questions?

Then visit us on brita.net

* This water filter system is tested for lead, copper, chlorine and carbonate hardness according to DIN EN 17093:2018 (limescale is certified to be reduced for 120l).



- DE** BRITA SE
AT Heinz-Hankammer-Straße 1
BE D-65232 Taunusstein
NL Verbraucherservice:
 Tel.: +49 800 500 19 19
- GB** BRITA Water Filter Systems Ltd.,
 BRITA House, 9 Granville Way,
 Bicester, Oxfordshire,
 OX26 4JT, UK
- IE** Bluestone Sales and Distribution Ltd.
 26 Oaktree Business Park
 Trim, Co. Meath,
 C15 HK40
 Ireland
- CH** BRITA Wasser-Filter-Systeme AG
 Gassmatt 6
 CH-6025 Neudorf/LU
 Verbraucherservice/Telephone
 client/Servizio di assistenza
 ai consumatori:
 041 932 42 00
- IT** BRITA ITALIA S.r.l
 Via Zanica, 19K
 I-24050 Grassobbio (BG)
 Tel: +39 035 203 447
 Numero Verde: 800 913 716
 Fax: +39 035 199 62 232
- FR** BRITA France S.A.R.L. 52,
 Boulevard de l'Yerres,
 91030 EVRY Cedex, France,
 N° Azur 0810 73 15 45
- ES** BRITA Iberia S.L.U.,
PT Carrer de Valencia, 307, 2. 4.,
 08009 - Barcelona
- GI** Khubchands Ltd.
 55 Main Street
 GX11 1AA
 Gibraltar
- MT** Miller Distributors Ltd.
 Miller House, Triq
 L-Esportaturi, Zone 2 Mrieħel
 Birkirkara CBD 2040
 Malta
- TR** BRITA TURKEY SU
 COZUMLERI, LIMITED ŞİRKETİ
 Kucukbakkalkoy Mh. Kayışdağı
 Cd. No:1 Allianz Tower, K:4 D:13
 PK:34750 Ataşehir - İstanbul
 +902163315076
 Müşteri Hizmetleri:
 +08504700740
- CY** Apostolos Papadopoulos Ltd.
 7 Danaou Street
 2045 Strovolos, P.O. Box. 22209
 1518 Nicosia
 Cyprus
- GR** Δ. Τσάκωνας
 K. Μόνος Α.Ε.
 Ζήνωνος 10 ΒΙ.Π.Ε., Κορωπίου
 Αττικής, Τ.Κ. 19441
 Greece
 Tel. +30 210 6627000
- DK** WITT A/S
FI Godstrup Sovej 9
NO 7400 Herning
SE Denmark
 Tel. +45 7025 2323
- EE** AQUA PURITY OU
LT Kullerkupu 17, EE
LV 50412 Tartu
 Estonia
 Tel. +370 63006417
- PL** BRITA Polska Sp. z o.o.
 Ołtarzew, ul. Domaniewska 6,
 05-850 Ożarów Mazowiecki,
 Polska
 Tel.: +48 22 721 24 40
 Faks: +48 22 721 24 49
- CZ** Potten & Pannen
 Staněk group
 a.s., Obchodní 110
 251 01 Čestlice
 Czech Republic
 Tel. +420 26122 7373
- SK** Potten & Pannen
 Staněk s.r.o.
 Plynarenska 6/a
 821 09 Bratislava
 Slovakia
 Tel. +421 252 632227
- SI** Bogart d.o.o.
 Pšata 81a, 1262 Dol pri Ljubljani
 Slovenia
 Tel. +386 15628227
- HR** PROMOMARK d.o.o.
 Andrije Kačića Miošića 17
 10410 Velika Gorica
 Croatia
 Tel. +385 15614083
- BA** Dotea d.o.o.
RS Stjepana Radica 9
ME 88000 Mostar
 Bosnia and Herzegovina
- MK** Canmak DOO Skopje
KO Balzakova 5/9
 1000 Skopje
 North Macedonia
- RO** Kitchen Shop SRL
MD Bulevardul Lacul Tei nr. 1-3
 cladirea ISPE, etaj 5, Sector 2
 020371 Bucuresti
 Romania
- HU** Kitchen Shop KFT
 Vaci ut 45. F. ep. 7. em.
 1134 Budapest
 Hungary
 Tel. +36 1445 3975
- BG** ВРИТА ООД
 ул. Княз Борис I, No. 2
 em.1, офис 1, гр. Бургас 8000
 България, Bulgaria
 Tel. +359 56 840967
- AL** Eurobrands SH.P.K.
 RR. Petrit Radovicka
 God. 145, Njesia II
 PO Box 1507 Tirane
 Albania
- GE** Power and Beauty LLC
AZ Lortkipanidze 18
 0114 Tbilisi
 Georgia
 Tel. +995 32 2103093
- AM** Narim LLC
 Bashingagian 1 str. 13/54
 0088 Yerevan
 Armenia
 Tel. +374 91004641
- KZ** LLP «AsiaSuCompany»
 Almaty city
 Gogol Street 140/13
 Kazakhstan
 Tel. +7 777 122 88 77
- UA** ТОВ СВІТ-УКРАЇНА
 03067 Україна
 Київ, вул. Олекси Тихого 42А
 офіс 310
 Ukraine
 Tel. +380 44531 4313
- SY** Venice Trading
 Abed St. P.O. Box 5711
 Damascus
 Syria
- LB** Helou Trading
 Fouad Chehab Str., Sin-el-Fil
 P.O. Box 55308
 Beirut
 Lebanon
- TN** Grintech s.a.r.l.
 Route Z4, Z.I. Saint Gobain
 1009 Jebel Jeloud
 Tunisia
- AE** 4Homes FZCO
 Gold & Diamond Park, Building 4
 Office 133, PO Box 61379
 Dubai, United Arab Emirates
 Tel. +971 3807611
- OM** FMCG Muscat
 LLC, P.O. Box 901
 PC 114 Jibroo
 Oman
- ZA** Aperture Importer Trading CC
 Unit 6, Meadowbrooke Estate
 Jacaranda Avenue, Olivedale,
 Randburg 2185 Gauteng
 South Africa
- NG** Superb Luxury Products Limited
 9th Floor, St. Nicholas House
 26 Catholic Mission Street
 101223 Lagos
 Nigeria